

Oxford[®] Presence

To avoid injury, read user manual prior to use.



Contents

1. The Oxford Presence Patient Lift.....	3
2. Introduction: About Your Lift.....	4
3. Assembly and Commissioning Instructions.....	5
4. Safety Precautions.....	9
5. Standard Control Box & Handset.....	11
6. Smart Monitor & Handset.....	12
7. Operating Instructions.....	16
8. Removal of Spreader Bar/Cradle Systems.....	19
9. Charging Instructions.....	21
10. Maintenance Schedule & Daily Check List.....	22
11. Technical Specifications.....	24
12. Warranty.....	27

1. The Oxford Presence Patient Lift

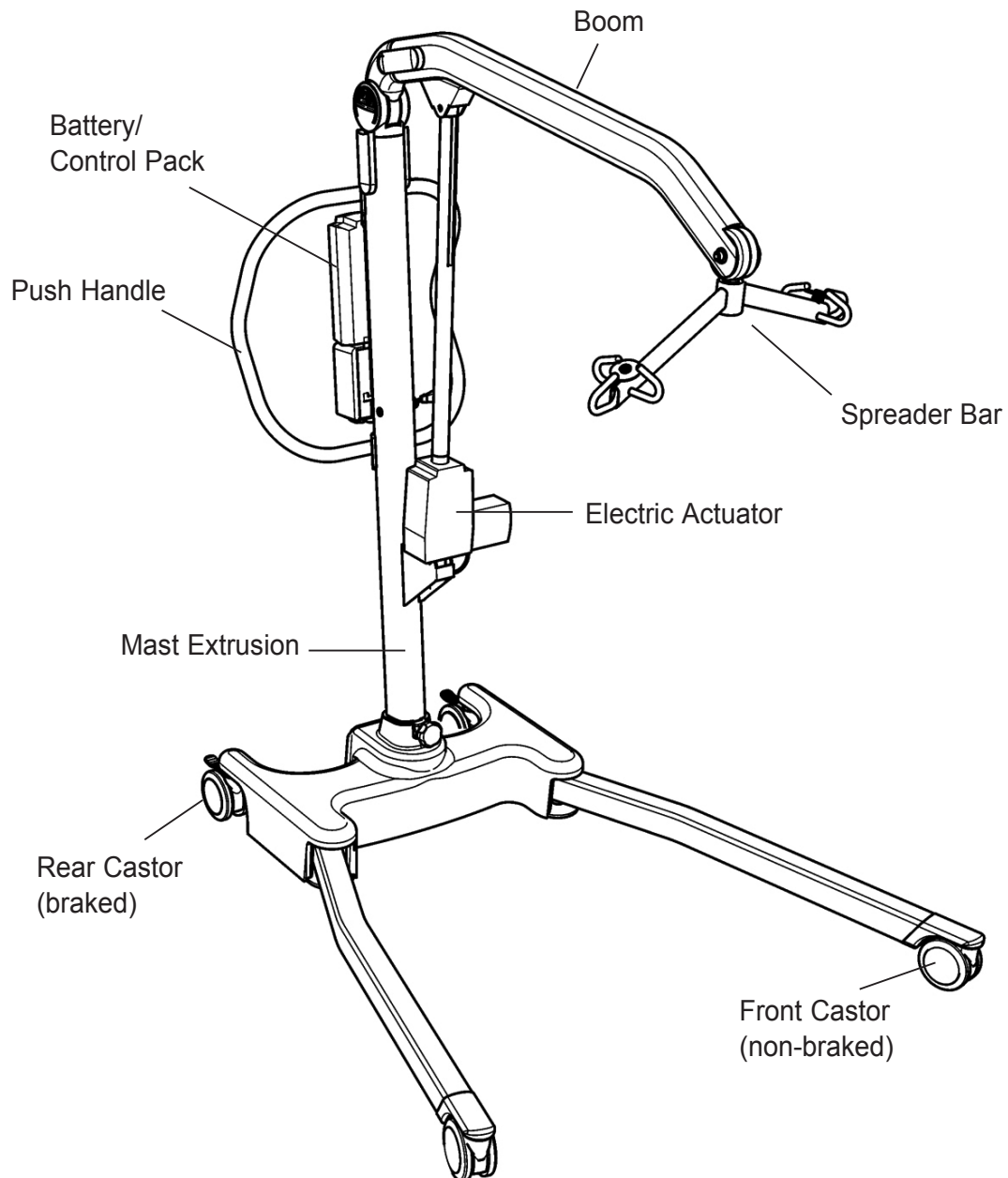

2. Introduction: About Your Lift

Each Presence lift is fully assembled, load tested and certified before being packed/shipped.

The packing consists of a strong, purpose built carton that is used for both export and domestic markets to ensure the safe arrival of the lift. A number of documents are supplied in a wallet, and packed with each lift and should be kept safely for future reference.

- TEST CERTIFICATE
- USER MANUAL

The TEST CERTIFICATE is an important document and should be kept for reference purposes.

To properly maintain your lift please refer to the maintenance schedule included in this document. If you are at all unsure what your country's servicing requirements are, please check with your dealer and/or a local government agency.

Statement of Intended Use

The intended use of this lifting device is for the safe lifting and transfer of an individual from one resting surface to another (such as a bed to a wheelchair). Joerns Healthcare recommends that the transfer of a patient is fully risk assessed and conducted safely over a short distance only.

The Oxford Presence is suitable for patients in the SITTING, SITTING/RECUMBENT and RECUMBENT positions.

The Oxford Presence is an electrically operated patient lift, designed to support and promote safe patient handling and transfer for both the patient and carer.

The Oxford Presence lift incorporates a 6-point cradle as standard and is designed to be used in conjunction with the Oxford range of slings. A 4-point cradle option is available as an add-on accessory. The examples of slings suitable for use with this device are listed as follows:

- Oxford Quickfit
- Oxford Full Back
- Oxford Quickfit Deluxe
- Oxford Long Seat
- Oxford Access
- Oxford Comfort

Expected Service Life

Oxford Professional lifts are designed and tested for a minimum service life of ten (10) years, subject to the use and maintenance procedures stated in this manual. Use, other than in accordance with these instructions, may compromise service life.

3. Assembly and Commissioning Instructions

Carton Contents

Place the carton in a clear working area and open carefully. The carton contains:

- OXFORD PRESENCE LIFT
- BATTERY PACK
- WALLET CONTAINING DOCUMENTS
- CHARGING LEAD
- HAND CONTROL
- DESK TOP CHARGER/STAND



WARNING

The Oxford Presence is heavy and will need to be lifted with care. You may need assistance to lift the Oxford Presence from the carton.

Assembly Instructions

1. Remove all the parts from the carton and place on the floor, taking care to protect the finish from damage.

Place the chassis in a clear space and apply the rear bakes.

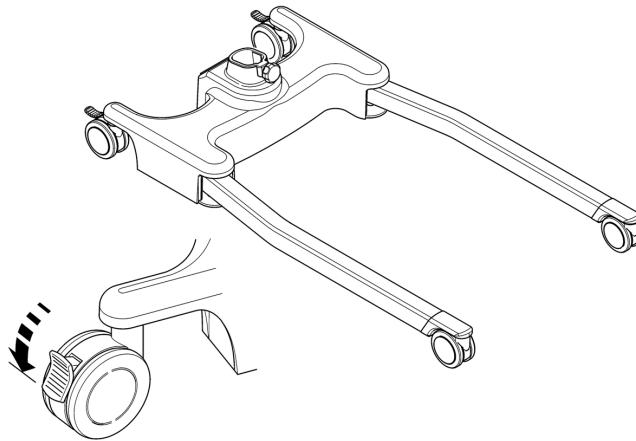

2. Fit the mast and boom assembly into the chassis socket.

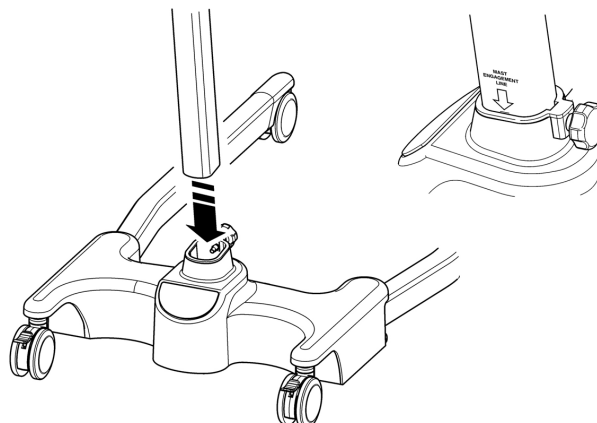

3. Tighten the mast assembly with the mast-locking device, which is located at the front of the chassis.

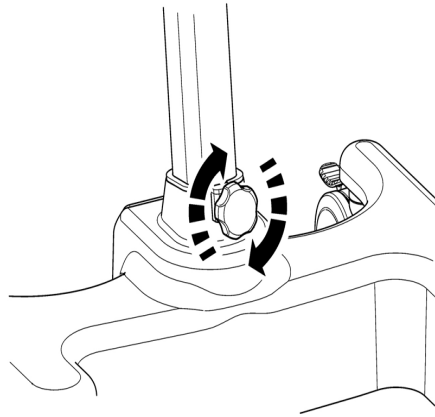

Avoid trapping fingers. Keep fingers away from the end of the mast when inserting into the chassis socket. Full engagement of the mast is indicated by the label on the side of the mast. The electric leg operation will not function unless the mast is fully engaged.

4. Turn the locking knob until hand tight.
5. Line the handle assembly up to the rear of the mast, and attach using the screws provided. The screws and wrench needed to attached the handle are kept in the user instruction wallet for safe keeping.

Note: When attaching the handle to the mast be sure that all trailing wires are left outside the handle before fixing.

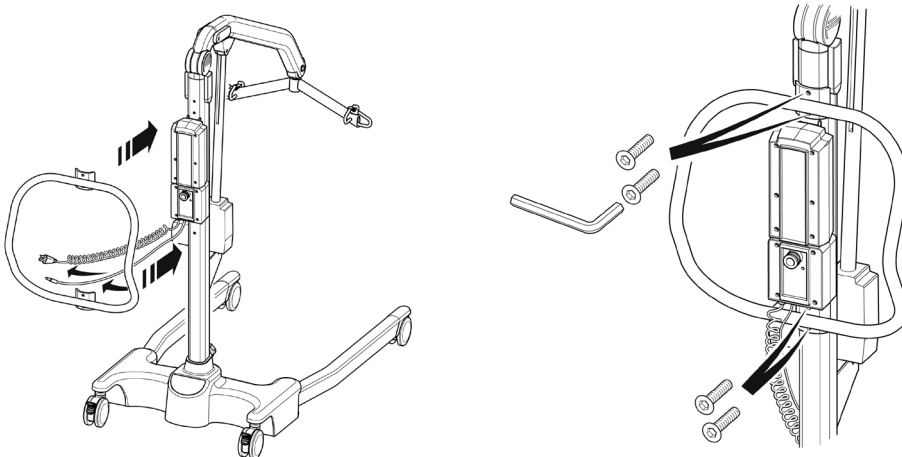

6. Fit power pack to the lift and make sure the latch holding the pack in place is fully engaged. “Click” in place.
7. Plug the handset and actuator cables into the bottom of the controller. Refer to the figures on page 11 or 12 for correct positions.

Disassembly

The lift should not be disassembled unless for service, repair or transport if necessary. If disassembly is required, simply follow the assembly instructions in reverse sequence.

ALWAYS CHECK THE FOLLOWING BEFORE OPERATION

- The mast is fully locked into position.

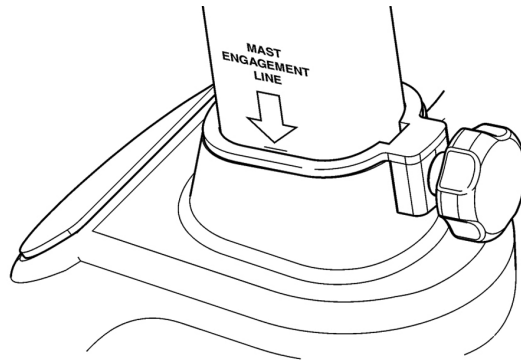

- The legs of the lift open and close satisfactorily (This is done via the hand control).

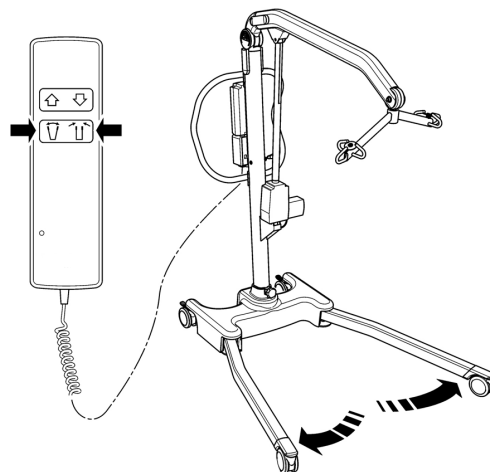

- The red emergency stop button, located on the rear of the control box, is in the OFF (out) position.

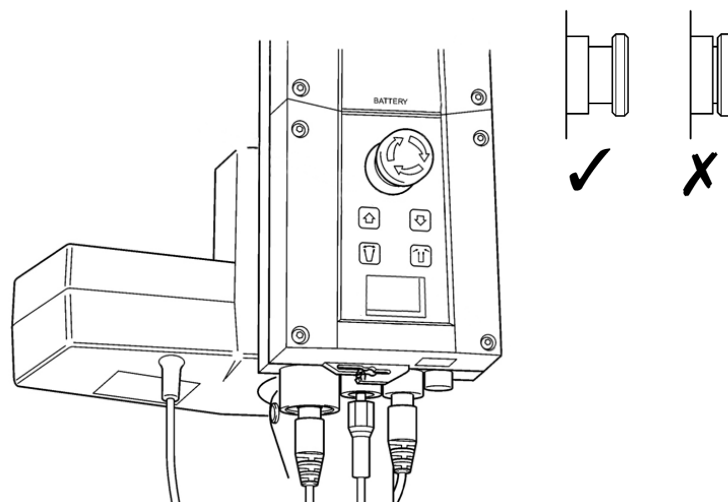

- Push the up and down buttons on the hand control and confirm the boom rises and lowers.

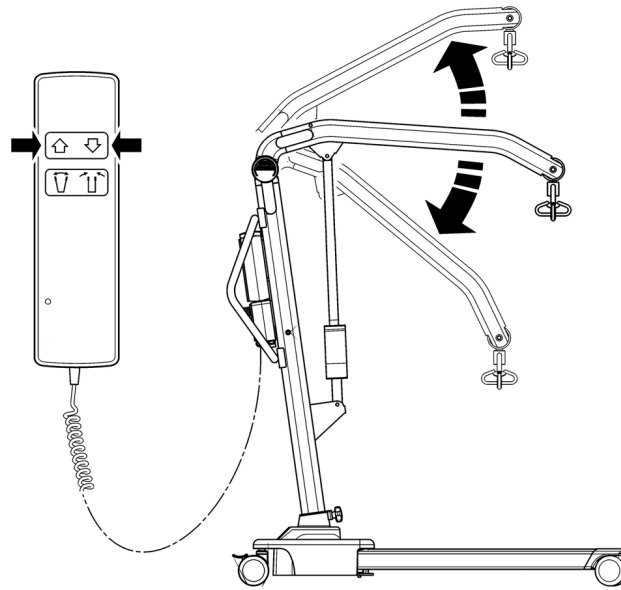

4. Safety Precautions

Please read and follow the safety precautions listed below. The operation and use of Oxford patient lifts is simple and straightforward. Following these few basic safety precautions will make lifting operations easy and trouble free.

READ AND UNDERSTAND THE USER INSTRUCTION MANUAL BEFORE USING THE OXFORD PRESENCE LIFT

WARNING: Important safety information for hazards that might cause serious injury.

CAUTION: Information for preventing damage to the product.

NOTE: Information to which you should pay special attention.

WARNING

- DO NOT lift a patient unless you are trained and competent to do so.
- ALWAYS carry out the DAILY CHECK LIST located towards the end of the manual before using the lift.
- DO NOT exceed the safe working load of the lift.
- ALWAYS plan your lifting operations before commencing.
- ALWAYS familiarize yourself with the operating control and safety features of a lift before lifting a patient.
- DO NOT use a sling unless it is recommended for use with the lift.
- ALWAYS check the sling is suitable for the particular patient and is of the correct size and capacity.
- NEVER use a sling, which is frayed or damaged.
- ALWAYS fit the sling according to the instructions provided (user instructions).
- ALWAYS check the safe working load of the lift is suitable for the weight of the patient.
- ALWAYS carry out lifting operations according to the instructions in the user manual.
- NEVER disconnect or bypass a control or safety feature because it seems easier to operate the lift.
- ALWAYS lock the wheels when lifting from the floor.
- DO NOT attempt to manoeuvre the lift by pushing on the mast, boom or patient.
- ALWAYS manoeuvre the lift with the handle provided. A foot push pad is also provided.
- DO NOT push a loaded lift at speeds, which exceed a slow walking pace (2.6 ft/sec).

- DO NOT push the lift over uneven or rough ground. Particularly if loaded.
 - DO NOT attempt to push/pull a loaded lift over a floor obstruction.
 - NEVER force an operating/safety control. All controls are easy to use and do not require excessive force.
 - DO NOT park a loaded lift on ANY sloping surface.
 - DO NOT use electric lifts in a shower.
 - DO NOT use or store a lift in a wet or corrosive environment such as shower, bath or pool locations.
 - DO NOT charge batteries in a bathroom or shower room.
 - DO NOT place or store batteries under direct sunlight or near a heat source.
 - YOUR lift is for patient lifting. DO NOT use it, or allow it to be used, for any other purpose.
 - DO NOT bump the lift down steps, loaded or unloaded.
 - DO NOT attempt to negotiate a loaded lift on a slope, which exceeds 1:12 (approximately 5 degrees)
 - DO NOT attempt to negotiate a slope without a second helper being present.
 - DO NOT use a loaded lift on thick pile carpet.
 - NEVER operate the lift with loose or missing parts or fasteners.
 - INSPECT all precautionary labels on the lift. Order and replace all labels that cannot be easily read.
-

5. Standard Control Box & Handset

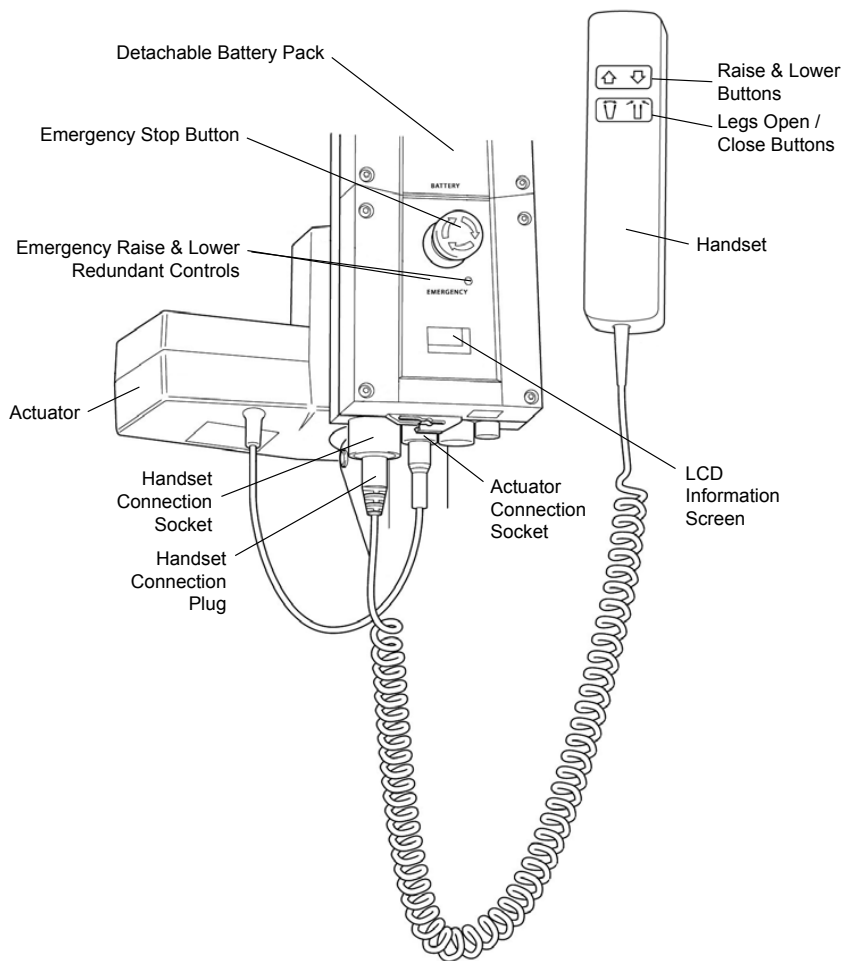

6. Smart Monitor & Handset

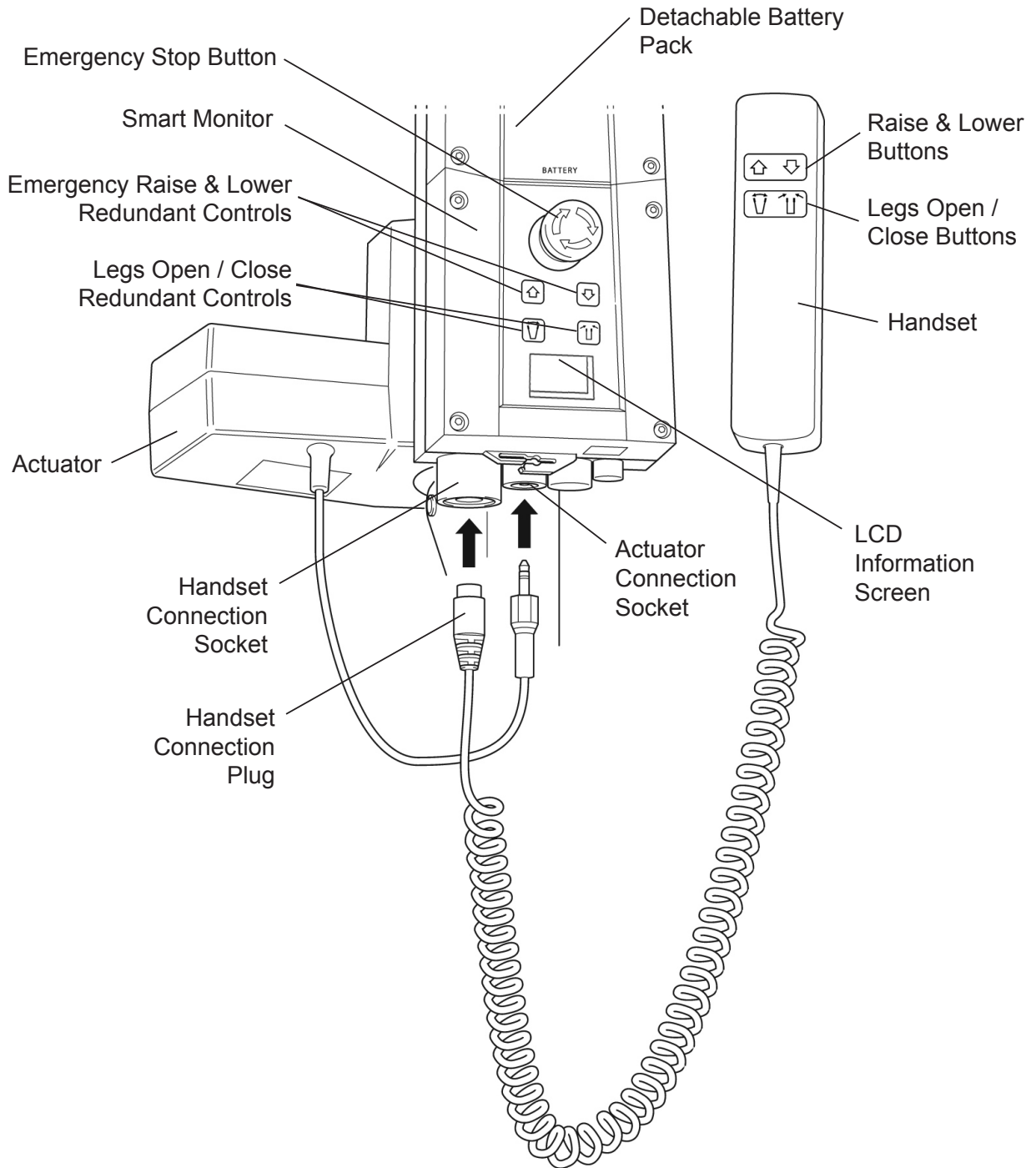

Intended Use

The Smart Monitor is a control system for Oxford lifts. The Smart Monitor stores useful servicing information about the lift that can be recalled when required. This servicing information includes:

- Number of patient lift cycles
- Total work done by actuator
- Number of lift overloads (attempted lifts above the safe working load)
- Number of days since last service interval

The Smart Monitor contains a microprocessor inside making it possible to read out service data via the on-board LCD screen.

Features

- Data collection in the control box with data display via LCD screen
- Work counter
- Intelligent cycle counter
- Service indicator
- Service interval indicator
- Overload information
- 3 step battery indicator



Benefits

- Improved safety for both patient and carer
- Accurate service data available at the touch of a button
- Optimised product life time
- Ease of maintenance for engineers and service technicians

LCD Display Screen

The Oxford Smart Monitor has the option to read out information via the LCD display screen. It is possible to read out total lifting cycles, total work done, overloads and number of days since last service, which can be used to quickly and easily evaluate the condition of the lift actuator.

This information is accessed by a 1/2 second press on the 'UP' button on the User handset or redundant 'UP' button on the Smart Monitor.

	12034 -----	Total Lifting Cycles
A - S	1257000 -----	Total Work Done (Amps * Seconds)
	7 -----	Number of Overloads
	90/360 -----	Number of Days (since last service) / Number of Days (between services)

Service & Usage Information



When it is time for a service, the service symbol will appear on the display. In addition, when the user handset is activated, the Smart Monitor will give an audible signal giving notice to users that a PM check is recommended (see recommended maintenance schedule later in this manual).

The service symbol will be displayed each time the raise or lower keys are depressed on the user handset.

To reset the service interval to one year, depress the leg open and leg close keys simultaneously for five seconds.



If the lift stops because of an overload (an attempt to lift more than the safe working load) the overload symbol will appear on the LCD display and the lift will cease. Lower the boom and remove excess weight.



If the LCD display screen on your Smart Monitor has recorded an overload, Joerns Healthcare recommend that ALL routine daily checks are carried out on the lift prior to further use (for a list of daily checks, please refer to your lift user manual). Joerns Healthcare also recommend that you contact your authorised Oxford service provider for additional guidance.

On-Board Redundant Controls

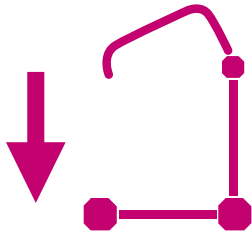

On-board redundant controls enable the lift to be raised or lowered in the event of an emergency.



If your lift incorporates powered leg positioning, there are redundant controls to both open and close the legs.

Battery Information

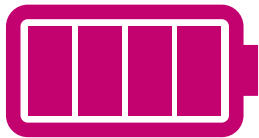

The display showing full battery means that the battery is fully charged and the lift is ready for use.



The display showing a half empty battery indicates that it is time to charge the battery.

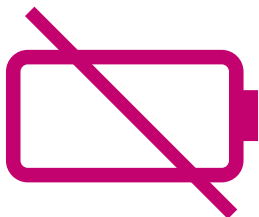

The empty battery symbol showing on the display indicates that the battery has no capacity left and should be placed on charge immediately.



WARNING

To avoid possible permanent damage to the battery, the battery should be placed on charge as soon as the display indicates the half empty battery symbol.

7. Operating Instructions

1. Leg Adjustment

The legs on the Oxford Presence are electrically adjustable for width. The legs can be opened to enable access around armchairs or wheelchairs. For transferring and negotiating narrow doorways and passages the lift legs should be in the closed position.

Electric leg adjustment - is achieved by pressing the appropriate buttons on the hand control. The legs will be locked whenever the hand control switch is released.

2. Castors and Braking

The lift has two braked castors which can be applied for parking. When lifting, the castors should be left free and un-braked. The lift will then be able to move to the centre of gravity of the lift. If the brakes are applied it is the patient that will swing to the centre of gravity and this may prove disconcerting and uncomfortable.

3. Raising and lowering the boom

The movement of the boom is achieved by a powerful electric actuator, which is controlled by a simple hand control unit. The hand control has two buttons with directional arrows UP and DOWN. The actuator stops automatically at the limit of travel in both directions. The hand control plugs into a socket at the base of the control box. There is a hook on the rear of the hand control, which allows it to be “parked” on the mast or boom when not in use.

4. Emergency Stop

The red Emergency Stop Button is located on the front of the control box and is activated by pressing in. This will cut all power to the lift and only be reset by twisting the button counter clockwise and releasing.

5. Redundant controls

All Oxford lifts are fitted with raise and lower buttons on the control box. These are located underneath the emergency stop button and can be used to lower/raise the patient should the hand control fail.

6. Mechanical Emergency Down

In the case of a complete electrical failure the electrical actuator is fitted with a mechanical lowering device (RED BOSS). Dependent on your lift, the device is either pulled upwards, or twisted by hand to activate. A slow decent will commence. Repeat this process until the patient has been safely lowered.



WARNING

If this feature is used, the lift **MUST** be subsequently checked out by a competent engineer.

7. Batteries

The batteries are protected from deep discharge by a LOW VOLTAGE ALARM. This will sound when the batteries need recharging and the hand control is being operated. It will not sound independently of the hand control being operated. CAUTION: DO NOT IGNORE THIS WARNING ALARM. Complete the lifting operation and place the lift on charge (see charging instructions).



WARNING

To avoid possible permanent damage to the battery, the battery should be placed on charge as soon as the display indicates the half empty battery symbol.

8. Slings

The Oxford Presence has the option of both a 6-point spreader bar and a 4-point positioning cradle. Both systems use different attachment methods and slings.

The 6-point system uses slings with webbing loops, which allow positioning adjustment by selecting different coloured loops. The 4-point cradle uses the Securi3 safety clip system and adjustment is made by rotating the 4-point cradle either upward or down.

Loop strap slings: Oxford Quickfit, Full Back, Quickfit Deluxe, Long Seat, Access and Silkfit

Safety clip slings: Oxford Comfort

The 6-point system attaches to the spreader bar hooks via loop straps (shown below), each sling is supplied with instructions. Please study the instruction guide before use.

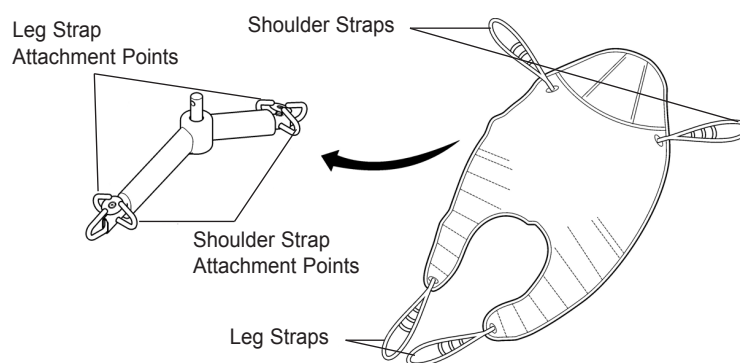

6-point spreader bar. Example of 6-point spreader bar sling with loop attachments.

The four point cradle sling attaches to the cradle studs via a safety clip system (shown below), each sling is supplied with instructions. Please study the instruction guide before use

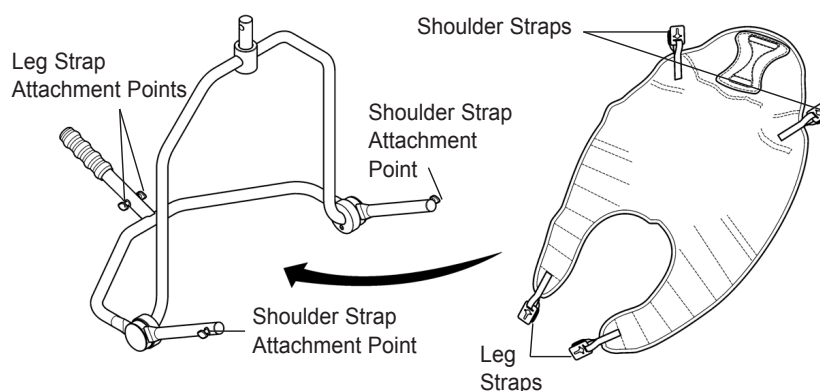

4-point positioning cradle.

Example of 4-point cradle sling with safety clip system.

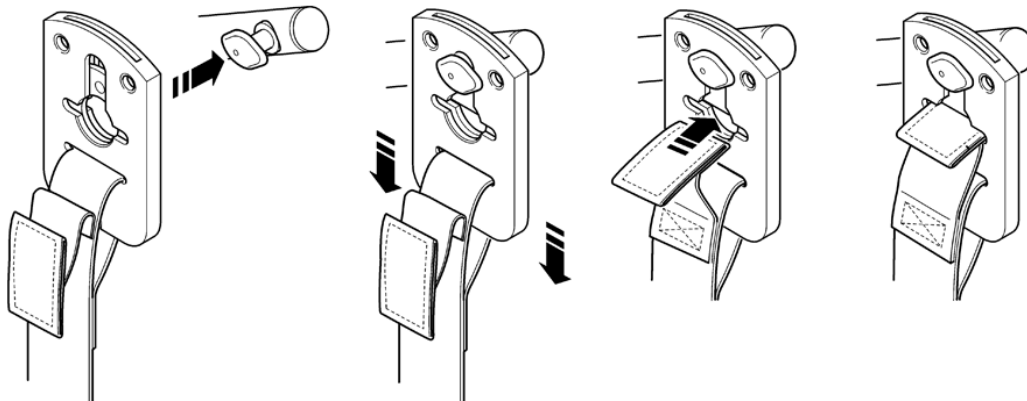

Securi3 sling attachment system. Example of installation.

Note: For detailed fitting instructions, please refer to the user guide supplied with each sling.



WARNING

Joerns Healthcare recommends that slings be checked regularly and particularly before use for signs of fraying or damage. **DO NOT** use slings that are worn or damaged.



WARNING

OXFORD RECOMMENDS THE USE OF GENUINE Oxford PARTS. Oxford sling and lifters are not designed to be interchangeable with other manufacturer's products. Using other manufacturer's products on Oxford products is potentially unsafe and could result in serious injury to patient and/or caregiver.



WARNING

Refer to maximum weight capacity of lift. Sling capacity is limited by the maximum capacity of the lift.

8. Removal of Spreader Bar/Cradle Systems

FOLLOW THESE INSTRUCTIONS EXACTLY

Your presence lift has the option of using both a 6-point spreader bar and 4-point positioning cradle. The removal of either of these systems is completed easily by the use of a quick-release pin. This is done quickly and easily, but you must read the following safety instructions to ensure the spreader bar/cradle is safely locked into position before use.

Connection

To connect, raise the spreader bar/cradle up toward the boom slot.

Insert the pin sleeve through the plastic end cap and to support the spreader bar/cradle.

Once aligned in the boom slot reinsert the quick release pin fully into the sleeve until it locks into position. **YOU MUST CHECK THAT THE PIN IS SECURELY FITTED.**

To do this, press your finger into the barbed end. If the pin remains stationary the lift is safe to use.

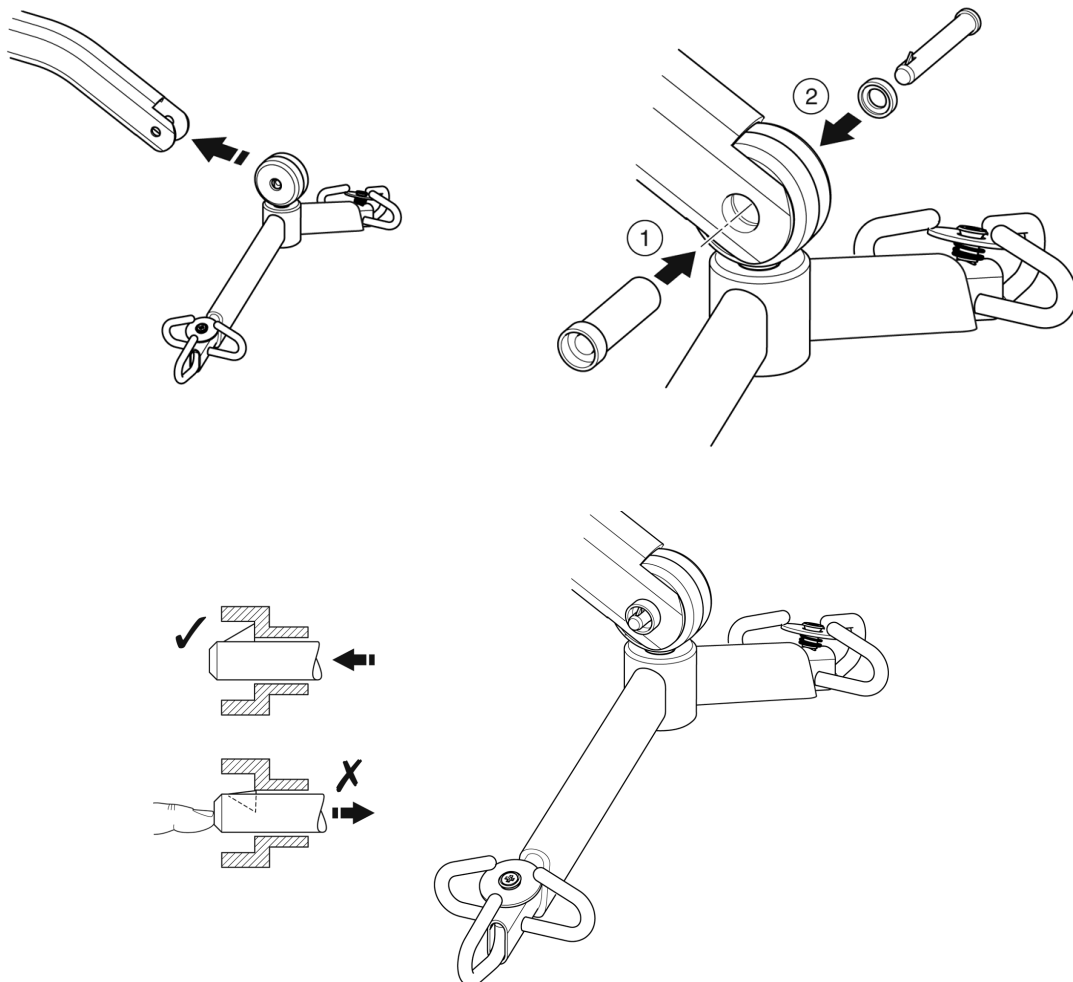

REMOVAL



CAUTION

Be sure to support the weight of the spreader bar/cradle before removing pin.

To detach pin, depress the spring barb (using a flat blade electrical screw driver or similar) and pull the pin out.

Support the spreader bar/cradle, and then pull the pin sleeve in the opposite direction, removing it completely from the boom. This will release the spreader bar completely.

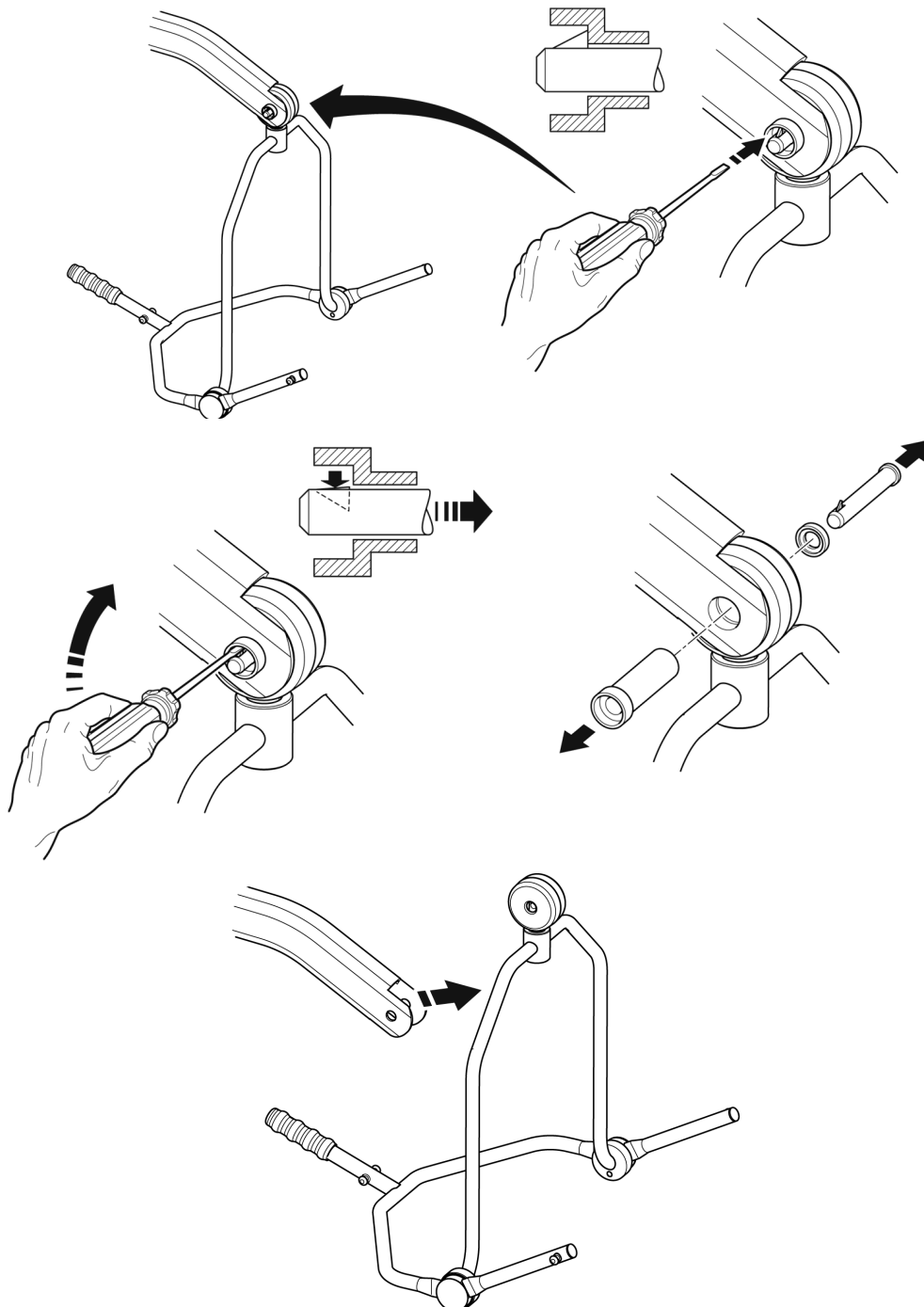

9. Charging Instructions

When the power pack needs charging it is removed from the lift and fitted to an off board charging unit.

1. Remove the power pack from the lift. The pack is retained by a simple latch at the top of the power pack. Lift the latch and the power pack will be released.
2. Fit the power pack to the charging unit. The location and latching of the power pack to the charger is the same system as used on the lift.
3. Plug the charger mains plug into a suitable mains outlet and switch the mains supply ON.
4. Charging is automatic and will fully charge the batteries over a period of four (4) hours.

Note: Even if the charger is left plugged in for extended periods it will not allow the batteries to overcharge.

- a) Green Light - Indicates main power is on.
- b) Yellow Light - Indicates battery is charging.
- c) Battery will be fully charged when yellow light goes off.

Note: It is recommended that the battery be charged immediately upon receipt.

5. To return the lift to service, unplug the charger and remove the power pack from the charger. Fit the power pack to the lift and make sure the latch holding the pack in place is fully engaged. "Click" in place. The charging of Hoyer electric lifts is simple and straightforward, but it is important to follow the charging instructions closely. Please pay particular attention to the following points, they will help you avoid problems with discharged batteries.

WARNING

- The battery, charger, hand control and control box are NOT to be opened by unauthorised personnel. (Contact your distributor for warranty and repairs).
- DO NOT touch battery/charger terminals.
- KEEP the batteries fully charged. Place the battery on charge whenever it is not in use. If it is more convenient to do so, place on charge every night. The charger will not allow the batteries to overcharge.
- NEVER run the batteries completely flat. As soon as the audible warning sounds, complete the lifting operation in hand and place on charge.
- To avoid possible permanent damage to the battery, the battery should be placed on charge as soon as the display indicates the half empty battery symbol.
- NEVER store the battery for long periods without regular charging throughout the storage period.
- NEVER leave the battery pack connected with the charger unit unplugged.

- Do NOT leave the charger plugged in with no battery connected.
- Never disconnect the charger plug by pulling on the cable.
- Be careful not to trip over the charge lead.
- Do not charge batteries in a bathroom or shower room.

10. Maintenance Schedule & Daily Checklist

All Oxford products are designed for minimum maintenance, however some safety checks and procedures are required. A schedule of DAILY tasks are detailed below. Daily checks and a yearly service, inspection and test will ensure a lift is kept in optimum safe working condition. A list of spare parts is available upon request.

DAILY CHECK LIST: Joerns Healthcare strongly recommends the following checks be carried out on a daily basis and before using lift.

- MAKE sure the lift moves freely on its castors.
- MAKE sure the spreader bar is free to rotate and swing. Check the spreader bar is firmly attached to the boom.
- ENSURE the mast is fully engaged into the mast slot and the mast locking device is securely tightened.
- EXAMINE the sling hooks on the spreader bar and side suspenders for excessive wear. If in doubt do not use.
- MAKE sure the legs open and close correctly.
- OPERATE the hand control to confirm the boom raises and lowers satisfactorily.
- CONFIRM the lift is not giving a low battery indicator when the hand control is operated. If a low battery is indicated, DO NOT use and place on charge immediately.
- Check the operation of the emergency stop button.
- EXAMINE slings for fraying or other damage. DO NOT use any sling if damaged or if the sling shows signs of wear.

MAINTENANCE

Joerns Healthcare recommends regular inspection and maintenance. Please refer to the chart on the next page.

*These checks should include:

✓ = Recommended

	Initially	Before Use	Service Intervals
1. SPREADER BAR: Check the spreader bar for freedom of rotation and swing. Check for wear on the central pivot. Check for firm attachment to the boom.	✓	✓	✓
2. BOOM: Check the attachment of the boom to the mast. Make sure there is only minimal side movement of the boom and the boom is free to rotate on the boom bearing.	✓	✓	✓
3. MAST: Check the operation of the mast-locking device. Make sure the mast fully engages into the socket. Check the bottom actuator.	✓	✓	✓
4. ACTUATOR: The actuator should require no maintenance other than checking for correct operation and listening for unusual noise.			✓
5. SMART MONITOR: Check the function of the emergency stop button. Inspect the hand control socket for correct fitting. Check functioning of the hand control. Check the redundant controls and confirm they operate as intended.	✓	✓	✓
6. BATTERIES: The batteries are housed in the power pack and should not require maintenance other than the regular charging as detailed in the charging instructions. Check that the connections remain clean.			✓
7. LEG ADJUSTMENT: Check the legs operate in both full extensions (inward/outward).	✓	✓	✓
8. CASTORS: Check all castors for firm attachment to the legs. Check for free rotation of the castor and the wheels.	✓	✓	✓
9. CLEANING: Clean with ordinary soap and water and/or any hard surfacem disinfectant. Harsh chemical cleaners or abrasives should be avoided as these may damage the surface finish of the lift. Avoid wetting any of the electrical parts.		✓	✓
10. LOAD TEST: The load test should be carried out in accordance with the manufacturer's test procedures. It is strongly recommended the testing is carried out by an authorised service dealer.			✓
11. BASE AND WHEELS: Ensure base is even and level (all four wheels are on the floor).	✓	✓	✓
12. SLINGS: Check for wear and fraying.	✓	✓	✓
13. LUBRICATION: Oil pivot joints, including mast and boom connections, pedal assembly, spreader bar joint (only if required).			✓
14. HAND SET: Ensure plugged fully into controller.	✓	✓	
15. QUICK RELEASE PIN: Ensure the pin is securely fitted before lifting, by pressing the barbed end.	✓	✓	
16. FIXINGS: Check all nuts, bolts, screws and fasteners for excessive wear and for tightness. Replace as required.			✓

11. Technical Specifications

Safe Working Load	500 lbs	227 kgs
Maximum Overall Length	57.5 inches	1460 mm
Minimum Overall Length	55.1 inches	1400 mm
Maximum Overall Height	81.3 inches	2065 mm
Minimum Overall Height	57.5 inches	1460 mm
Spreader Bar Maximum Height	75.2 inches	1910 mm
Spreader Bar Minimum Height	16.9 inches	430 mm
Height at Maximum Reach	51.5 inches	1310 mm
Reach at Maximum Height	25.6 inches	650 mm
Reach at Minimum Height	15.7 inches	400 mm
Maximum Reach*	36.6 inches	930 mm
Turning Radius	64.2 inches	1630 mm
Legs Open - External Width	45.2 inches	1150 mm
Legs Open - Internal Width	40.1 inches	1020 mm
Legs Closed - External Width	26.4 inches	670 mm
Legs Closed - Internal Width	21.6 inches	550 mm
Overall Height of Legs	4.7 inches	120 mm
Overall Height of Low Legs (option)	2.4 inches	60 mm
Ground Clearance	1.4 inches	35 mm
Front Twin Castors	4 inches	100 mm
Rear Braked Castors	4 inches	100 mm

* Reach = centre of spreader bar to the front of the mast

4-point Positioning Cradle (measurement to top of location pins)

Cradle Max. Height	61 inches	1550 mm
Cradle Min. Height (usable).	15.4 inches	390 mm

Weights

Mast, Base & Boom Assembly (includes 2 point spreader bar)	81.4 lbs	37 kgs
Power Pack	6.6 lbs	3 kgs
Total	88 lbs	40 kgs
Base Assembly (not inc battery)	44 lbs	20 kgs
Mast & Boom (not inc battery)	37.4 lbs	17 kgs
4-point Position Cradle	13.2 lbs	6 kgs

All measurements are within a +5/--5 degree of tolerance.

Electrical Specifications:

BATTERIES.....	24 volt Rechargeable sealed lead acid type
BATTERY CAPACITY.....	3.2 Ampere hours
CHARGER RATED INPUT.....	100 - 240 V AC/ 50/60 Hz
CHARGER RATED OUTPUT.....	29.5 VDC, Max. 19 W

Electric Shock Protection

CHARGER.....	CLASS II (EN 60601-1)
LIFT.....	INTERNAL POWER SOURCE

Degree of Shock Protection

CHARGER.....	TYPE B (EN 60601-1)
LIFT.....	TYPE B (EN 60601-1)

Environmental Conditions:

Outside this environment functionality and safety may be compromised.

Operating :

Temperature	5°C to 40°C
Relative humidity.....	20% to 90% @ 30°C - not condensing
Atmospheric pressure.....	700 to 1060 hPa

Storage :

Temperature	-10°C to +50°C
Relative humidity	20% to 90% @ 30°C - not condensing
Atmospheric pressure	700 to 1060 hPa

IP Ratings

Control Box	IPX4
Actuator	IPX4
Off Board Charger	IPX5
Battery	IPX5
Handset	IPX4

Duty Cycles

Actuator	10% (2 min./18 min.)
Charger	Approx. 4 hrs.

Acoustics

A-Weighted sound power level	60 dB (A)
------------------------------------	-----------

KEY SYMBOLS:

The following symbols are used on the charger, control unit and battery:



Type B equipment, as per EN 60601-1



Class 2 equipment



The disposal of the charging and control unit should not be mixed with general household waste

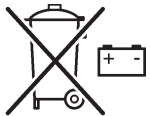

The disposal of batteries should not be mixed with general household waste.



The disposal of electronics should not be mixed with general household waste



For indoor use



ATTENTION, consult accompanying documents.

WEEE Producers registration number WEE/GG0464RZ

12. Warranty

This warranty covers HoyerPro lifts only. Lifts not covered under this warranty include, but are not limited to Advance-H, HML400, HPL600WB, HPL600WBSC, HPL402, C-HLA (and variations).

HoyerPro lifts are guaranteed for a period of two years from the date of delivery against defects in materials and workmanship under normal use and service. This warranty includes all mechanical and electrical components.

Aluminium structural components and mechanical components on lifts are covered under warranty for a period of five (5) years from the date of delivery.

Damage caused by use in unsuitable environmental conditions or failure to maintain the product in accordance with user and service instructions is not covered. Any alteration, modification or repair unless performed by or authorized in writing by Joerns Healthcare will void this warranty.

Parts:

HoyerPro lifts contain various parts that wear from normal use. These parts, such as DC batteries and casters are not covered under the two-year warranty but are covered for 90 days after date of delivery.

Joerns Healthcare's obligation under this warranty is limited to supplying replacement parts, servicing or replacing, at its option, any product which is found by Joerns Healthcare to be defective.

Warranty replacement parts are covered by the terms of this warranty until the product's original warranty period expires.

When requested by Joerns Healthcare, parts must be returned for inspection at the customer's expense. Credit will be issued only after inspection.

Service:

Most service requests handled by the facility Maintenance Department with assistance from the Joerns Healthcare Product Service Department.

Most parts requested can be shipped next day air at the customer's expense.

Should a technician be required, one will be provided by Joerns Healthcare, at our discretion. Only the Joerns Healthcare Product Service Department can dispatch authorized technicians.

This warranty is extended to the original purchaser of the equipment.

Your distributor:



2 Selgar Avenue, Tonsley SA, 5042

T 1300 350 350 | F 1300 350 360

sales@highgatehealthcare.com.au

highgatehealthcare.com.au

Through our innovative, quality products, exceptional service and ingrained knowledge and expertise of the healthcare industry, Highgate Healthcare has been raising the standard of living in aged care, hospital, disability and rehabilitation facilities in Australia for over 30 years.



Highgate Healthcare

1300 350 350

2 Selgar Avenue Tonsley SA 5042

highgatehealthcare.com.au